

SELECT CEDARMILL[®] • SMOOTH • COLONIAL SMOOTH[®] • COLONIAL ROUGHSAWN[®] • BEADED CEDARMILL[®] BEADED SMOOTH • STRAIGHT-EDGE SHINGLE PLANK

IMPORTANT: FAILURE TO INSTALL AND FINISH THIS PRODUCT IN ACCORDANCE WITH APPLICABLE BUILDING CODES AND JAMES HARDIE'S WRITTEN APPLICATION INSTRUCTIONS MAY LEAD TO PERSONAL INJURY, AFFECT SYSTEM PERFORMANCE, VIOLATE LOCAL BUILDING CODES, AND VOID THE PRODUCT ONLY WARRANTY.

STORAGE & HANDLING:

Store flat and keep dry and covered prior to installation. Installing siding wet or saturated may result in shrinkage at butt joints. Carry planks on edge. Protect edges and corners from breakage. James Hardie is not responsible for damage caused by improper storage and handling of the product.

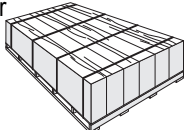

CUTTING INSTRUCTIONS

OUTDOORS

1. Position cutting station so that wind will blow dust away from user and others in working area.
2. Use one of the following methods:
 - a. Best:
 - i. Score and snap
 - ii. Shears (Pneumatic or Handheld)
 - b. Better:
 - i. Dust reducing circular saw equipped with a Hardiblade[®] saw blade and HEPA vacuum extraction
 - c. Good:
 - i. Dust reducing circular saw with a Hardiblade saw blade (only use for low to moderate cutting)

INDOORS

1. Cut only using score and snap, or shears (manual, electric or pneumatic).
2. Position cutting station in well-ventilated area

- NEVER use a power saw indoors
- NEVER use a circular saw blade that does not carry the Hardiblade saw blade trademark
- NEVER dry sweep – Use wet suppression or HEPA Vacuum

Important Note: For maximum protection (lowest respirable dust production), James Hardie recommends always using "Best"-level cutting methods where feasible.

NIOSH-approved respirators can be used in conjunction with above cutting practices to further reduce dust exposures. Additional exposure information is available at www.jameshardie.com to help you determine the most appropriate cutting method for your job requirements. If concern still exists about exposure levels or you do not comply with the above practices, you should always consult a qualified industrial hygienist or contact James Hardie for further information.

SD083105

GENERAL REQUIREMENTS:

- Hardiplank[®] lap siding can be installed over braced wood or steel studs spaced a maximum of 24" o.c. or directly to minimum 7/16" thick OSB sheathing*. Hardiplank lap siding can also be installed over foam insulation up to 1" thick. Irregularities in framing, sheathing, and/or foam insulation can mirror through the finished application
- A Weather-resistive barrier is required in accordance with local building code requirements. The weather resistive barrier must be appropriately installed with penetration and junction flashings in accordance with local building code requirements. James Hardie will assume no responsibility for water infiltration.
- Install James Hardie[®] products with a minimum 6" clearance to the finished grade on the exterior of the building or in accordance with local building codes if greater than 6" is required (fig. 3).
- Maintain a minimum 2" clearance between James Hardie products and roofs, decks, paths, steps and driveways (figs. 4 & 5).
- Maintain a 1/4" clearance between James Hardie products and horizontal flashing (fig. 6).
- Install kickout flashing at roof-wall junctions. (fig 7.) Ensure gutters have end caps and do not terminate against siding and trim.
- Adjacent finished grade must slope away from the building in accordance with local building codes - typically a minimum of 6" in the first 10'.
- Do not install James Hardie products, such that they may remain in contact with standing water.

Figure 1 Double Wall Construction Single Wall Construction

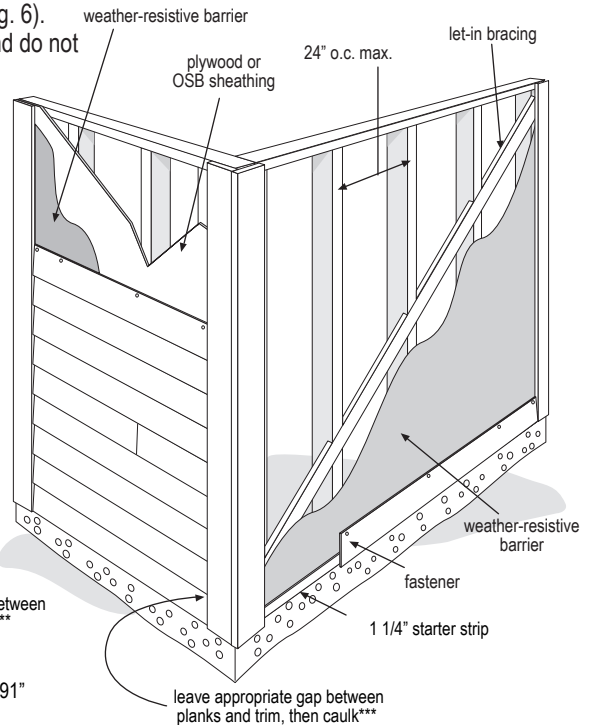

INSTALLATION:

Install a 1 1/4" starter strip to ensure a Consistent plank angle (Figure 1).

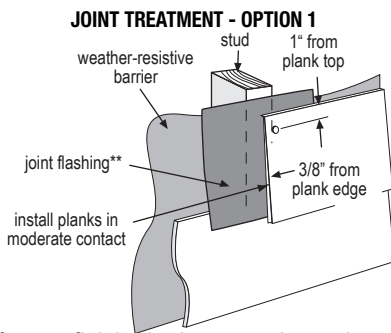

JOINT TREATMENT - OPTION 2 (Not applicable to ColorPlus[®] Finish)

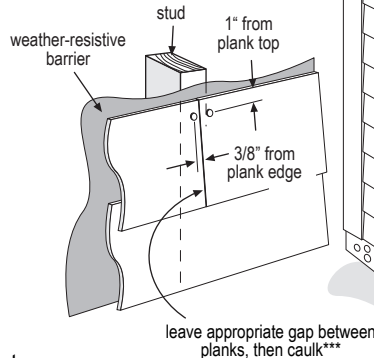

Install factory finished edges together at butt joints.

For other jointing options, refer to local building code or NER 405.

* If only nailed to sheathing, plank can be a maximum 9-1/4" wide and must face nailed at 12" o.c. with 0.091" shank x 0.221 HD x 1.5" long corrosion resistant nails.

As required by local building code *Apply caulk in accordance with caulk manufacturers written application instructions.

WARNING: AVOID BREATHING SILICA DUST

James Hardie[®] products contain respirable crystalline silica, which is known to the State of California to cause cancer and is considered by IARC and NIOSH to be a cause of cancer from some occupational sources. Breathing excessive amounts of respirable silica dust can also cause a disabling and potentially fatal lung disease called silicosis, and has been linked with other diseases. Some studies suggest smoking may increase these risks. During installation or handling: (1) work in outdoor areas with ample ventilation; (2) use fiber cement shears for cutting or, where not feasible, use a Hardiblade[®] saw blade and dust-reducing circular saw attached to a HEPA vacuum; (3) warn others in the immediate area; (4) wear a properly-fitted, NIOSH-approved dust mask or respirator (e.g. N-95) in accordance with applicable government regulations and manufacturer instructions to further limit respirable silica exposures. During clean-up, use HEPA vacuums or wet cleanup methods - never dry sweep. For further information, refer to our installation instructions and Material Safety Data Sheet available at www.jameshardie.com or by calling 1-800-9HARDIE (1-800-942-7343). FAILURE TO ADHERE TO OUR WARNINGS, MSDS, AND INSTALLATION INSTRUCTIONS MAY LEAD TO SERIOUS PERSONAL INJURY OR DEATH.

SD05905

CLEARANCES

Install siding and trim products in compliance with local building code requirements for clearance between the bottom edge of the siding and the adjacent finished grade.

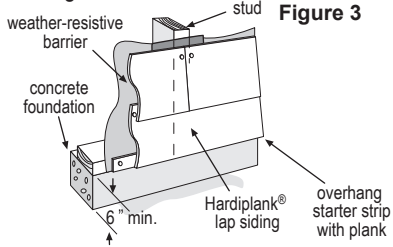

Figure 3

Maintain a minimum 2" clearance between James Hardie® products and decks, paths, steps and driveways.

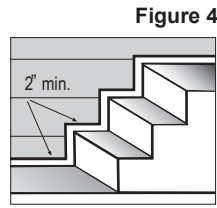

Figure 4

At the juncture of the roof and vertical surfaces, flashing and counterflashing shall be provided per the roofing manufacturer's Instructions. Provide a 2" clearance between the roofing and the bottom edge of the siding and trim.

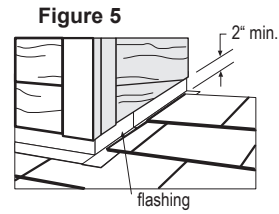

Figure 5

Maintain a 1/4" clearance between the bottom of James Hardie® products and horizontal flashing. Do not caulk gap.

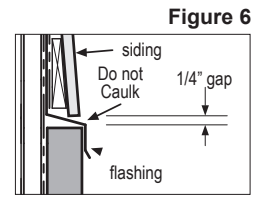
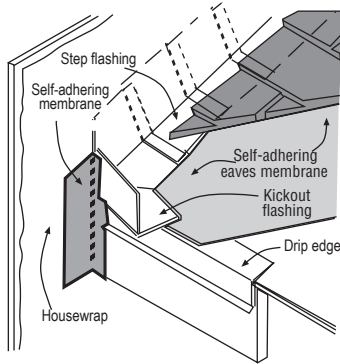

Figure 6

Figure 7



KICKOUT FLASHING

Because of the volume of water that can pour down a sloped roof, one of the most critical flashing details occurs where a roof intersects a sidewall. The roof must be flashed with step flashing. Where the roof terminates, install a kickout to deflect water away from the siding (figure 7).

It is best to install a full rubberized asphalt flashing on the wall before the subfascia and trim boards are nailed in place, and then come back to install the kickout.

Figure 7, Kickout Flashing[‡] To prevent water from dumping behind the siding and the end of the roof intersection, bend a small "kickout" from metal flashing to divert water running down the roof away from the siding.

FASTENER REQUIREMENTS**

FACE NAILING

Corrosion Resistant Nails (galvanized or stainless steel)

- 6d (0.113" shank x 0.267" HD x 2" long)
- Siding nail (0.089" shank x 0.221" HD x 2" long)
- Siding nail (0.091" shank x 0.221" HD x 1-1/2" long)*

Corrosion Resistant Screws

- Ribbed Wafer-head or equivalent (No. 8-18 x 0.323" HD x 1-5/8" long) Screws must penetrate 1/4" or 3 threads into metal framing.

Corrosion Resistant Fasteners

- ET & F pin (0.100" shank x 0.25" HD x 1-1/2" long)

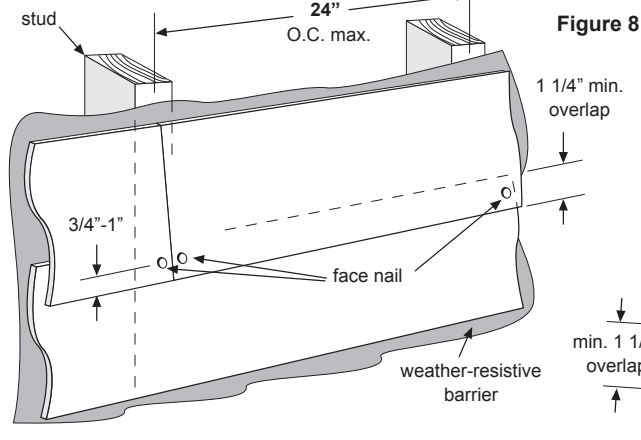

Figure 8

BLIND NAILING **

Corrosion Resistant Nails (galvanized or stainless steel)

- Siding nail (0.089" shank x 0.221" HD x 1-1/4" long)
- 11ga. roofing nail (0.121" shank x 0.371" HD x 1-1/4" long)

Corrosion Resistant Screws

- Ribbed Wafer-head or equivalent (No. 8-18 x 0.323" HD x 1 5/8" long) Screws must penetrate 1/4" or 3 threads into metal framing.

Corrosion Resistant Fasteners

- ET & F Panelfast™ (0.100" shank x 0.313" HD x 1-1/2" long)

Figure 9

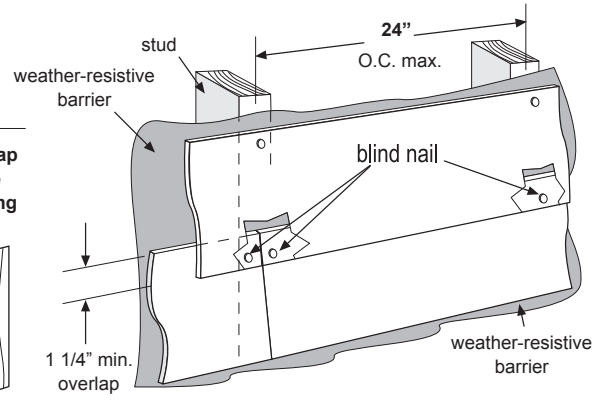

Minimum overlap
for Both Face
and Blind Nailing

min. 1 1/4"
overlap

Laminate sheet to be removed immediately after installation of each course.

[‡] The illustration (figure 7) and associated text was reprinted with permission of THE JOURNAL OF LIGHT CONSTRUCTION. For subscription information, call (800) 375-5981 or visit www.jlconline.com.

* When face nailing to OSB, planks must be no greater than 9 1/4" wide and fasteners must be 12" o.c. or less.

** Also see General Fastening Requirements.

GENERAL FASTENING REQUIREMENTS

Fasteners must be corrosion resistant, galvanized, or stainless steel. Electro-galvanized are acceptable but may exhibit premature corrosion. James Hardie recommends the use of quality, hot-dipped galvanized nails. James Hardie is not responsible for the corrosion resistance of fasteners. Stainless steel fasteners are recommended when installing James Hardie® products near the ocean, large bodies of water, or in very humid climates.

- Consult applicable code compliance report for correct fasteners type and placement to achieve specified design wind loads and shear values.
- NOTE: Published shear values and wind loads may not be applicable to all areas where Local Building Codes have specific jurisdiction. Consult James Hardie Technical Services if you are unsure of applicable compliance documentation.
- Drive fasteners perpendicular to siding and framing.
- Fastener heads should fit snug against siding (no air space). (Fig. A)
- Do not over-drive nail heads or drive nails at an angle.
- If nail is countersunk, caulk nail hole and add a nail. (Fig. B)
- Under driven nails should be hit flush to the plank with a hammer.
- **Do not use aluminum fasteners, staples, or clipped head nails.**

PNEUMATIC FASTENING

James Hardie products can be hand nailed or fastened with a pneumatic tool. Pneumatic fastening is highly recommended. Set air pressure so that the fastener is driven snug with the surface of the siding. A flush mount attachment on the pneumatic tool is recommended. This will help control the depth the nail is driven. If setting the nail depth proves difficult, choose a setting that under drives the nail. Drive under driven nails snug with a smooth faced hammer.

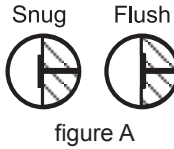

CUT EDGE TREATMENT

Caulk, paint or prime all field cut edges.

CAULKING

For best results use a latex sealant that complies with either ASTM C834 or ASTM C920 (Grade NS, Class 25). Caulking must be applied in accordance with the caulking manufacturer's written instructions.

PAINTING

James Hardie products must be painted.* 100% acrylic topcoats are recommended. Do not paint when wet. For application rates refer to paint manufacturers specifications. Back-rolling is recommended if the siding is sprayed. *within 180 days for primed product and 90 days for unprimed

COLORPLUS® TECHNOLOGY CAULKING, TOUCH-UP & LAMINATE

- Touch up nicks, Scrapes and nail heads using the ColorPlus® technology touch up pen. Touch-up paint should be used sparingly. If large areas require touch-up, replace the damaged area with new Hardiplank® lap siding with ColorPlus technology.
- Laminate sheet must be removed immediately after installation of each course.
- Terminate non-factory cut edges into trim where possible, and caulk. Color matched caulks are available from your ColorPlus dealer.
- Treat all other non-factory cut edges using the ColorPlus technology edge coat, available from your ColorPlus™ product dealer.

COVERAGE CHART/ESTIMATING GUIDE

Number of 12' planks, does not include waste

COVERAGE AREA LESS OPENINGS (1 SQ = 100 sq.ft.)	HARDIPLANK® SIDING WIDTH										
	(exposure)	5 1/4 4	6 1/4 5	7 1/4 6	7 1/2 6 1/4	8 6 3/4	8 1/4 7	9 1/4 8	9 1/2 8 1/4	12 10 3/4	
1		25	20	17	16	15	14	13	13	9	
2		50	40	33	32	30	29	25	25	19	
3		75	60	50	48	44	43	38	38	28	
4		100	80	67	64	59	57	50	50	37	
5		125	100	83	80	74	71	63	63	47	
6		150	120	100	96	89	86	75	75	56	
7		175	140	117	112	104	100	88	88	65	
8		200	160	133	128	119	114	100	100	74	
9		225	180	150	144	133	129	113	113	84	
10		250	200	167	160	148	143	125	125	93	
11		275	220	183	176	163	157	138	138	102	
12		300	240	200	192	178	171	150	150	112	
13		325	260	217	208	193	186	163	163	121	
14		350	280	233	224	207	200	175	175	130	
15		375	300	250	240	222	214	188	188	140	
16		400	320	267	256	237	229	200	200	149	
17		425	340	283	272	252	243	213	213	158	
18		450	360	300	288	267	257	225	225	167	
19		475	380	317	304	281	271	238	238	177	
20		500	400	333	320	296	286	250	250	186	
21		525	420	350	336	311	300	263	263	195	
22		550	440	367	352	326	314	275	275	205	
23		575	460	383	368	341	329	288	288	214	
24		600	480	400	384	356	343	300	300	223	
25		625	500	417	400	370	357	313	313	233	
26		650	520	433	416	385	371	325	325	242	
27		675	540	450	432	400	386	338	338	251	
28		700	560	467	448	415	400	350	350	260	
29		725	580	483	464	430	414	363	363	270	
30		750	600	500	480	444	429	375	375	279	

This coverage chart is meant as a guide. Actual usage is subject to variables such as building design. James Hardie does not assume responsibility for over or under ordering of product.

RECOGNITION: In accordance with ICC-ES Legacy Report NER-405, Hardiplank lap siding is recognized as a suitable alternate to that specified in: the BOCA National Building Code/1999, the 1997 Standard Building Code, the 1997 Uniform Building Code, the 1998 International One- and Two-Family Dwelling Code, the 2003 International Building Code, and the 2003 International Residential Code for One-and Two-Family Dwellings. Hardiplank lap siding is also recognized for application in the following: City of Los Angeles Research Report No. 24862, State of Florida listing FL#889, Dade County, Florida NOA No. 02-0729.02, U.S. Dept. of HUD Materials Release 1263c, Texas Department of Insurance Product Evaluation EC-23, City of New York MEA 223-93-M, and California DSA-PA-019. These documents should also be consulted for additional information concerning the suitability of this product for specific applications.

© 2005 James Hardie International Finance B.V. All rights reserved.
TM, SM, and ® denote trademarks or registered trademarks of
James Hardie International Finance B.V. ® is a registered trademark
of James Hardie International Finance B.V.

Additional Installation Information,
Warranties, and Warnings are available at
www.jameshardie.com

